

OXICOMP 1

OXYGEN COMPRESSOR WITH ELECTRONIC CONTROL

For cylinder filling.

Feed pressure according on model from 0,5 to 1,7 bar (7,25 to 24,65 psi)

Selectable filling pressure, maximum 170 bar (2,465 psi)

Maximum cylinder filling volume 1000 l/h (1 m³/h)

CEIMSA oxygen compressors have been developed incorporating the latest technology, making it possible to manufacture compressors of the highest quality and technological design, according the most demanding standards of safety and reliability for oxygen compressors.

These compressors performs EC standards requirements and are appropriate for the compression of oxygen, helium, nitrogen and other clean and dry gases at a selectable pressure of 100 – 150 - 170 bar (1450 – 2175 - 2465 psig.).

The high pressure OXICOMP oxygen compressors, oil-free, includes very low revolution-per-minute (RPM) special geared motors, making it possible to extend the time between maintenance checks.

The OXICOMP compressors use two external oil free floating pistons. These pistons are mounted, with the use of rods, on a transverse axis which acts as crankshaft, facilitating the easy removal of the cylinder-piston-rod assembly for maintenance operations.

The pistons may be very easily dismantled in order to carry out a replacement or a simple change of segments (rings). Similarly, there are external stainless steel valves, linings and o-rings manufactured with anti-explosion treatment and designed for heavy-duty work.

The particular characteristics and innovating system of gas compression make our compressors unique, not only in terms of their design and quality, but also in their robustness and reliability, setting them apart from other compressors in the market.

*Oxygen Compressor
Low RPM
Oil-Free*

O₂

OXICOMP 1 TECHNICAL CHARACTERISTICS	
Maximum filling pressure	170 bar (2.465 psi)
Feed voltage	230-400V 50/60 Hz
Power of geared motor	1,1 Kw single phase (1,47 Hp)
RPM (very low)	28 RPM
Oxygen circuit	Cooled by Refrigerating Liquid and Air.
Gas connections	¼ " NPTF
Start/Stop	Manual or automatic by external control
Parallel Pistons System	Two pistons: Upper and Lower Piston.
External valves	Stainless steel and easy to replace
Electronic Control	Adjustment by pressure transducer
Electrovalve	Alleviation or decompression
Filling Ramp	Can be connected to a ramp with cylinders
Maintenance	Simple
Weight	140 Kg.
Dimensions	Length 460 x Breadth 460 x height 930 mm..



Rv. 3-15/02/11 Ceimsa reserves the right to change specifications or dimensions without prior notice.

MODELS AND SPECIFICATIONS

Blower	Model	Feeding Flow (l/min)	Input Pressure (bar)	Input Pressure (PSI)	Load Pressure (bar)	Load Pressure (PSI)	Flow (m3/h)	Flow (l/h)
OXICOMP 1	A	6	0,5	7,25	170	2465	0,3	300
	B	12	1	14,5	170	2465	0,6	600
	C	17	1,5	21,75	170	2465	0,9	900
	D	20	1,7	24,65	170	2465	1	1000

Other pressures and input can be regulated to be adapted to the customer needs

STANDARD COMPONENTS

- Electronic circuit
- Electric box
- Geared motors
- Lower piston
- Upper piston
- Refrigeration elements
- Start/Stop Buttons
- Emergency Stop
- Incoming oxygen deposit
- Incoming pressure regulator
- Pressure transducer
- Safety valve
- Decompression valve
- Antireturn Valve
- Refrigerant ventilator
- Crank

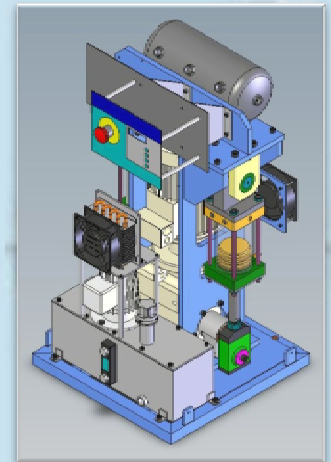

Patented System

AUTOMATISM IN THE FEED AND FILLING PRESSURE

This compressor works with a feeding pressure from 0,5 to 1,7 bar (7,25 to 24.65 psig.) so if the pressure falls below this assigned value, the compressor stops and remains on standby until the pressure rises again to this value at which it starts operating again. The compressor also automatically stops, and remains on standby, when the cylinders reach the pressure of 170 bars (2465 psig).

MAINTENANCE

The estimated lifespan for segments and o-rings at 200 bars is demonstrated to be 4,500 hours. The lifespan of segments and o-rings of the first stage is considerably greater. For maintenance work we recommend to have a spare set of o-rings and segments and a spare module (upper piston and lower piston) for quick replacements in case of checks or possible breakdowns.

RECOMMENDED SPARE PARTS:



Spare set of o-rings and segments

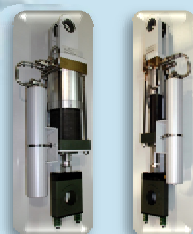

Spare module
Complete upper and lower pistons



Schematic example
For an oxygen cylinder filling plants